

# Eclipse Architectural®

exterior folding door systems



*Beautiful doors for beautiful spaces*

## E2i Interior Folding Door Hardware System

(No Sill Or Floor Channel Required)

**DS**Group

[www.theDSgroup.com](http://www.theDSgroup.com)

Tomorrow's Innovative Solutions for Today's Doors & Windows

The DS Group Of Companies: Draftseal®, Kristrack®, Eclipse Architectural® & DSD Hardware

# E2i Specifications

Max opening	26' (8m)
Max panel weight	90lb (40kg)
Max panel height	118" (3000mm)
Max panel width	3'3" * (39") (1000mm)
Min panel thickness	1-3/8" (35mm)
Max number of panels	8 (4 each direction)

\* 3 and 4 panel systems may require a specific operating sequence at the max panel width.



E2i internal bifold system without a bottom sill or floor channel is based on Eclipse's standard E2 hardware system and uses Centor's proven bifold window technology. For interior applications only, it is designed for seamless transitions between rooms and interior spaces. All the benefits of the versatile E2 system are preserved.

### E2i features include:

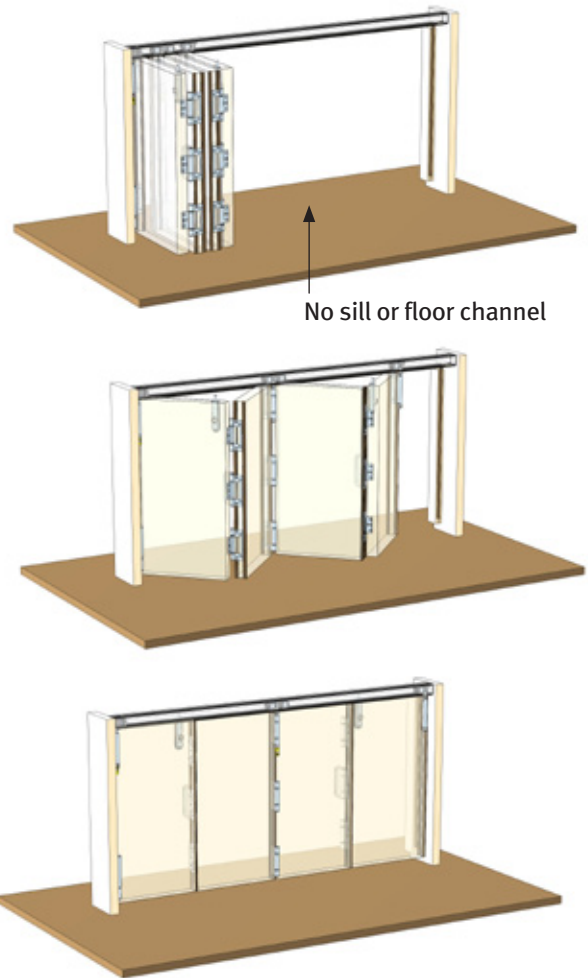
- Laterally adjustable bottom pivot
- All stainless steel construction
- No need for costly tile and concrete cutting
- Complete horizontal and vertical adjustment

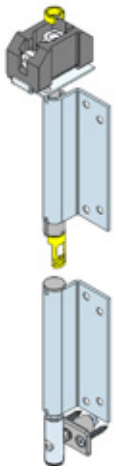
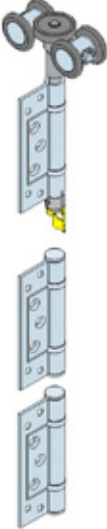
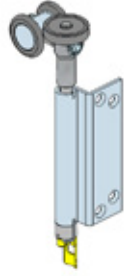
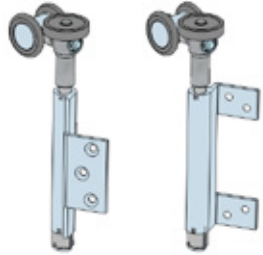

# E2i Components

<p><b>KTE2IBPPSS</b> Pivot set, stainless steel</p> 	<p><b>KTE2IBPICSS</b> Intermediate carrier set stainless steel</p> 	<p><b>KTE2IBPECSS</b> End carrier set stainless steel</p> 	<p><b>KTE2IBPMCSS</b> Meeting carrier set stainless steel</p> 	<p><b>KTE2HSS</b> Hinge set (flat) stainless steel</p> 	<p><b>KTE2HHSS</b> Hinge set (offset) stainless steel</p> 
---	--	---	--	--	---

# E2i Architectural Detail

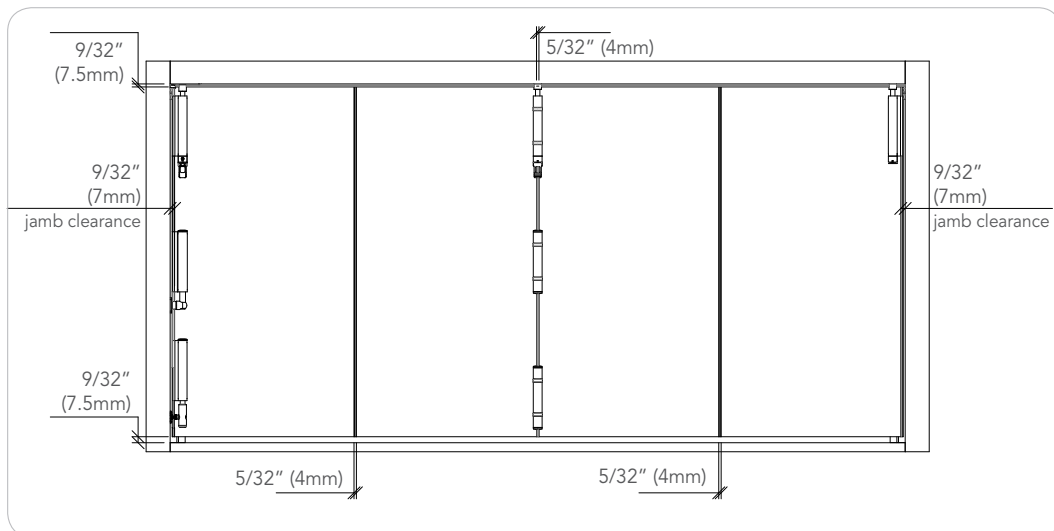
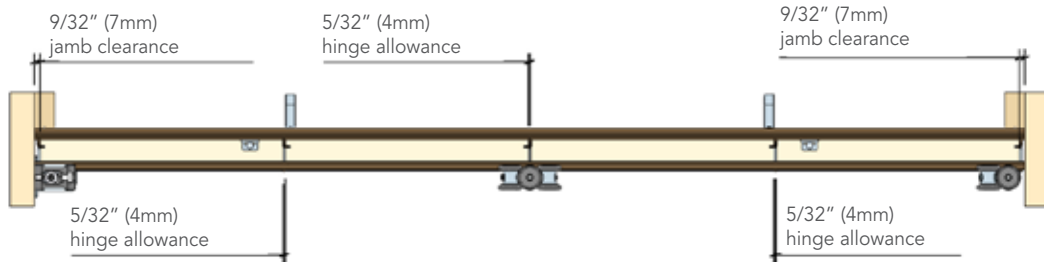
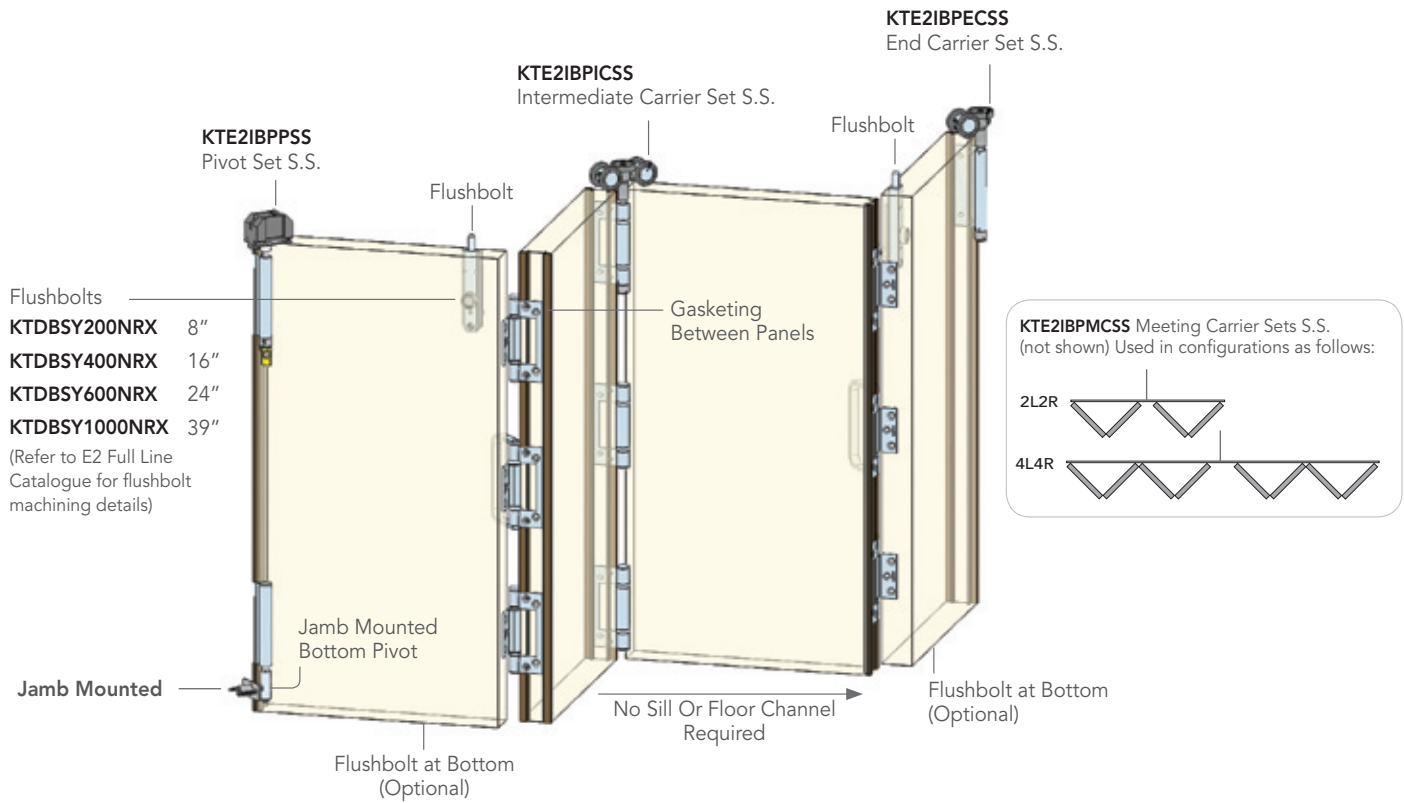

## KTE2i Cross Section

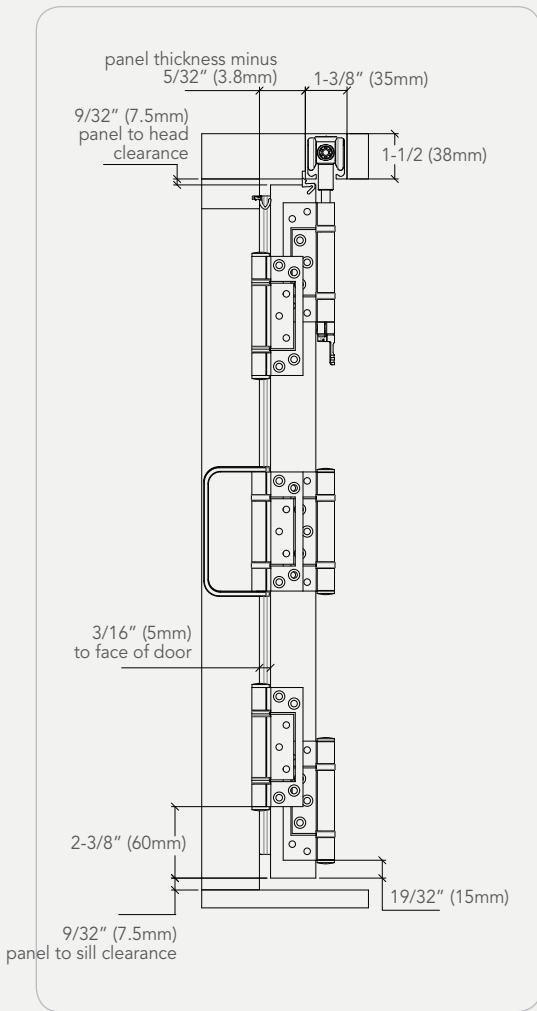

## KTE2i Top View

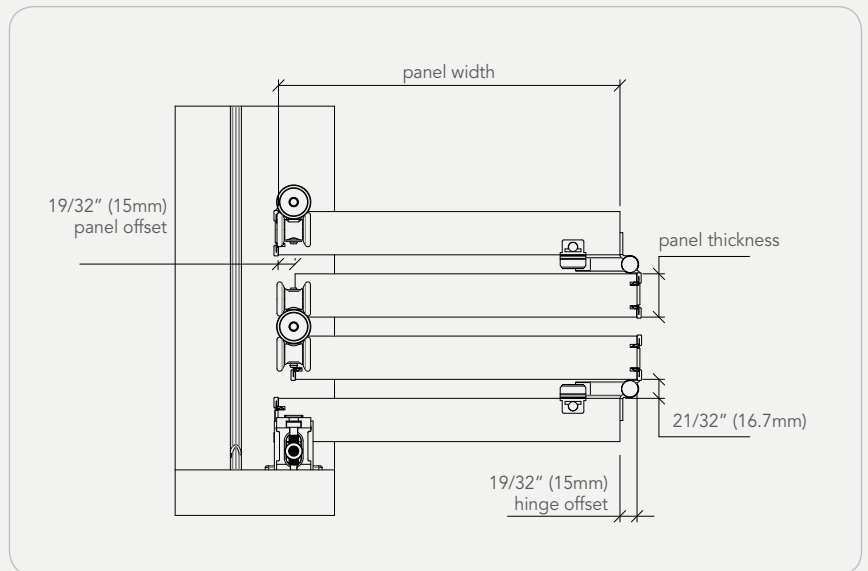

# DS Group

[www.theDSgroup.com](http://www.theDSgroup.com)

**Tomorrow's Innovative Solutions for Today's Doors & Windows**

**The DS Group Of Companies:** Draftseal®, Kristrack®, Eclipse Architectural® & DSD Hardware

### Head Office & Manufacturing Centre - Vancouver, Canada

7470 Buller Avenue, Burnaby, B.C. V5J 4S5 Canada

Phone: (604) 451-1080 • Fax: (604) 451-1140 • [info@theDSgroup.com](mailto:info@theDSgroup.com)

Outside Vancouver, B.C., please use our toll free numbers: Phone: 1-888-520-9009 Fax: 1-800-567-2887

### Branch Office & Manufacturing Centre - Toronto, Canada

1545 Britannia Road East, Unit 25, Mississauga, Ontario L4W 3C6 Canada • Local Fax: (905) 696-9623

### Branch Office & Distribution Centre - Los Angeles, California

7250 Bandini Blvd, Unit 107, Commerce, CA 90040 USA • Local Fax: (323) 246-4760

### Satellite Offices

Oregon & Hawaii, USA

### Eclipse Architectural® Corporate Showrooms

Vancouver & Toronto, Canada • Los Angeles, California & Honolulu, Hawaii USA

The DS Group is the brand image of A.K. Draft Seal Ltd.